

GUJARAT TECHNOLOGICAL UNIVERSITY**BE - SEMESTER-III(NEW) EXAMINATION – SUMMER 2023****Subject Code:3130608****Date:03-08-2023****Subject Name:Mechanics of Solids****Time:02:30 PM TO 05:00 PM****Total Marks:70****Instructions:**

1. Attempt all questions.
2. Make suitable assumptions wherever necessary.
3. Figures to the right indicate full marks.
4. Simple and non-programmable scientific calculators are allowed.

	Marks
Q.1 (a) Explain free body diagram with neat sketch.	03
(b) Write various systems of forces and explain coplanar concurrent force system.	04
(c) Determine magnitude and direction of resultant force of the force system shown in Fig.-1 .	07
Q.2 (a) Write the assumption made in analysis of truss.	03
(b) Define shear force and bending moment with sign conventions.	04
(c) Determine magnitude, direction and position of resultant force of the force system given in Fig.-2 with reference to point A.	07
OR	
(c) Draw shear force and bending moment diagram for the beam shown in Fig.-3 .	07
Q.3 (a) Differentiate in-between centre of gravity & centroid.	03
(b) Write equation of moment of inertia for rectangular section and triangular section about its neutral axis and base of section.	04
(c) Determine the centroid of the plane area shown in Fig.-4 .	07
OR	
Q.3 (a) Write assumption made in the theory of torsion.	03
(b) Find out radius of gyration for square section. Consider side dimension is 'B' mm.	04
(c) Find the moment of inertia about both centroidal axes of Z section as shown in Fig.-5 .	07
Q.4 (a) Write assumptions made in theory of pure bending.	03
(b) Draw shear stress distribution diagram for hollow rectangular, hollow circle and H section.	04
(c) Calculate the diameter of the shaft required to transmit 45 kW at 120 rpm. The maximum torque is likely to exceed the mean by 30% for a maximum permissible shear stress of 55 N/mm ² . Calculate also the angle of twist for a length of 2 m. $G = 80 \times 10^3 \text{ N/mm}^2$.	07
OR	
Q.4 (a) Define composite beam and give main objectives of it.	03
(b) A simply supported beam 300 mm x 600 mm of 6 m. span is subjected to UDL of 15 kN/m throughout the span. Find the maximum bending stress in the beam.	04
(c) Determine the shear stress at the junction of the flange & web of an 'I' section as shown in Fig.-6 . Consider shear force 20 kN.	07
Q.5 (a) Define with sketch (i) tensile stress (ii) compressive stress (iii) shear stress	03

- (b) State Hook's law. Explain stress-strain behavior of mild steel with sketch. **04**
(c) Determine the magnitudes & directions of principal stresses for two dimensional body as shown in **Fig.-7**. **07**

OR

- Q.5** (a) Explain deformation of uniform bar section under self weight. **03**
(b) Determine change in volume of a steel bar of 100 mm dia. and 500 mm length, when it is subjected to axial pull of 50 kN. Take $E_s = 200$ GPa. & poisson ratio 0.25. **04**
(c) Calculate change in volume of a rectangular block 525 mm x 230 mm x 115 mm is subjected to load as shown in **Fig.-8**. Consider poisson ratio 0.25 and E is 2×10^5 N/mm². **07**

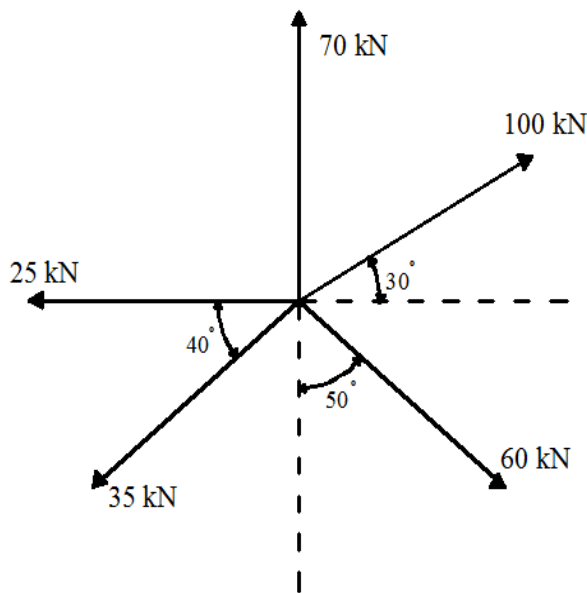

Fig. - 1

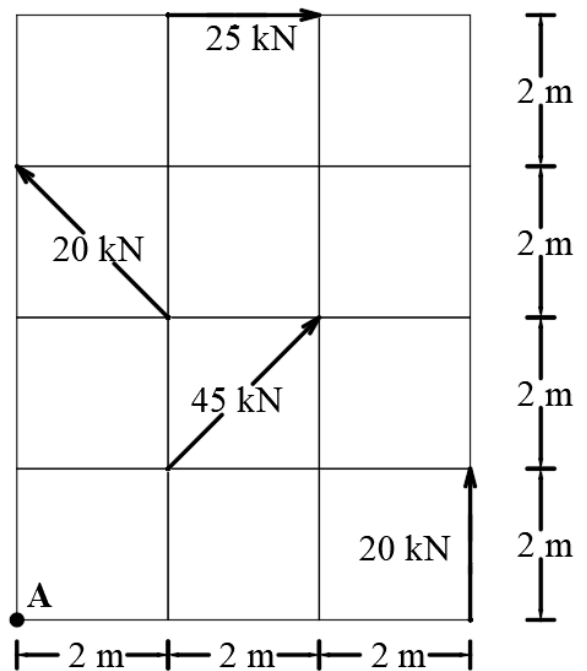

Fig. - 2

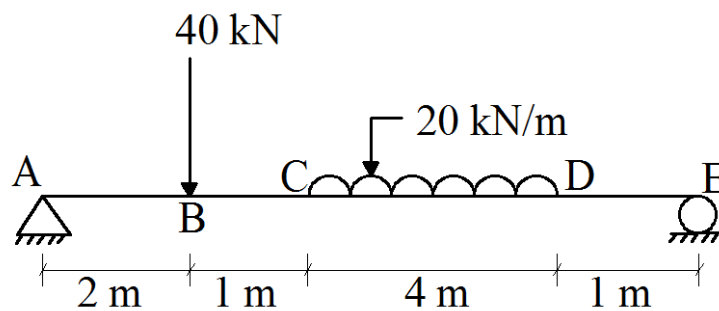

Fig. - 3

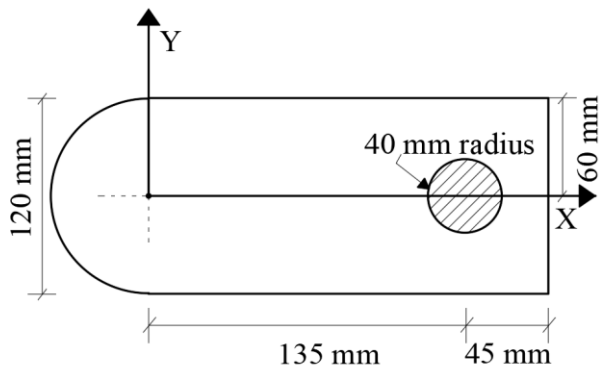

Fig. - 4

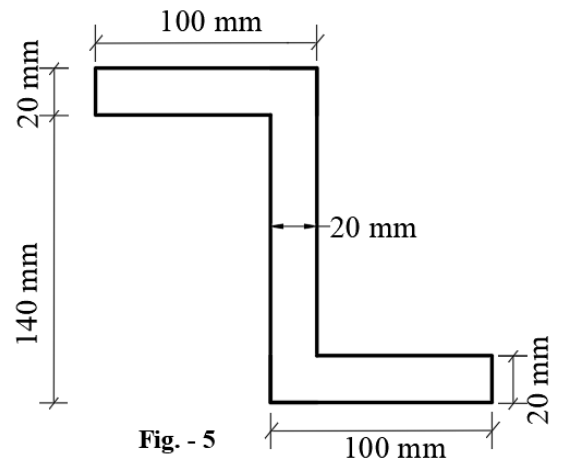

Fig. - 5

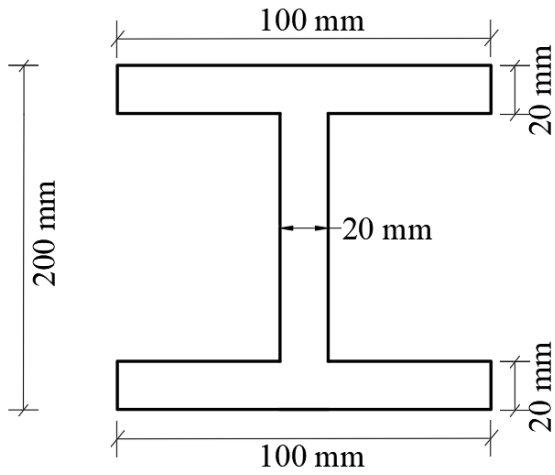

Fig. - 6

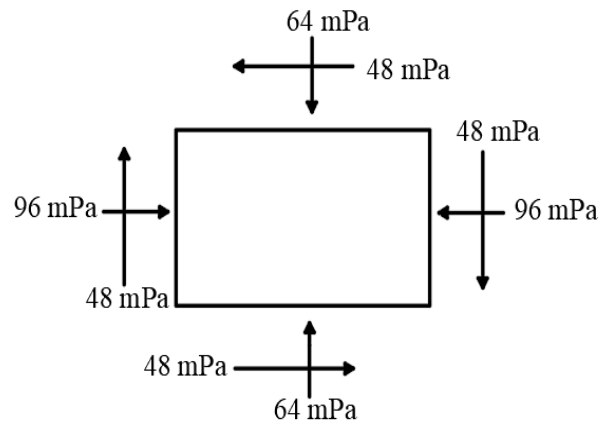

Fig. - 7

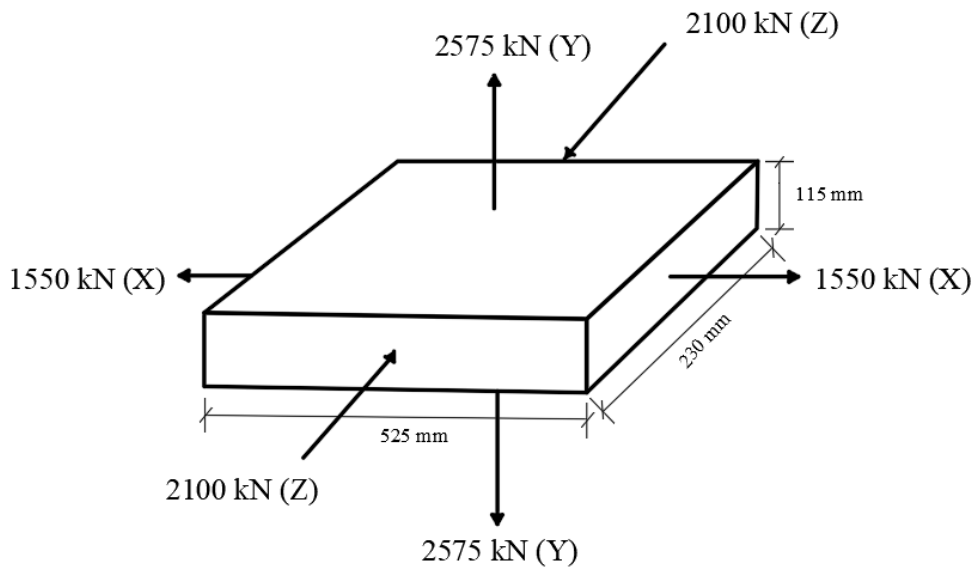

Fig. - 8